

BROTHER® HL-2700 • TN-04 CARTRIDGE REMANUFACTURING INSTRUCTIONS



BROTHER® HL-2700 PRINTER



BROTHER® TN-04 TONER CARTRIDGE



REMANUFACTURING THE BROTHER HL-2700CN TONER CARTRIDGE

By Mike Josiah

The Brother HL-2700CN printers are based on a 31-ppm black, 8-ppm color 600 dpi engine. The toner cartridges are simple to do, and quite profitable. These machines were designed as workgroup printers, and continued to be very popular.

One nice item to note on these cartridges is that they do not use a chip. There is also nothing to reset when installing them.

There are four separate color toner cartridges, one separate waste cartridge and a separate OPC belt unit used in these machines. The part numbers and current list pricing are listed below:

Cartridge	Part Number	List Price (USD)	Stated Yield
Black Toner	TN04K	\$187.99	10,000
Cyan Toner	TN04C	\$182.49	6,600
Magenta Toner	TN04M	\$182.49	6,600
Yellow Toner	TN04Y	\$182.49	6,600
Waste Pack	WT4CL	\$ 13.99	
OPC Belt	OP4CL	\$367.49	60,000

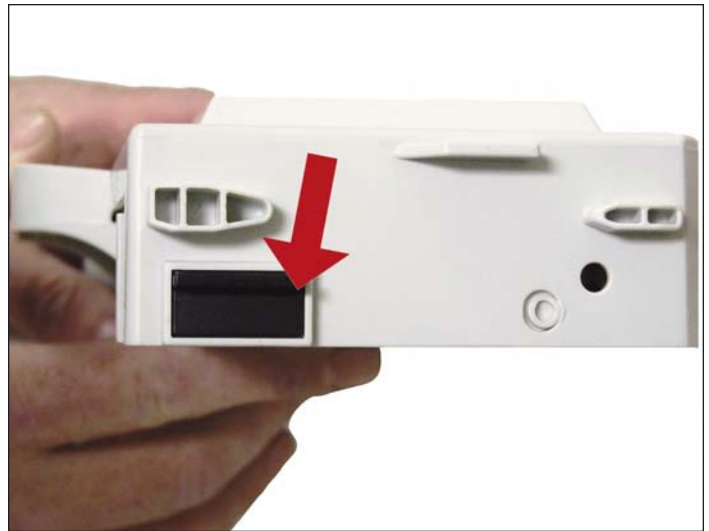

All four of the toner cartridges are different in that they each have unique tabs (see above photos) on the side that prevent one color from being inserted into another color's slot.

As the layout of these cartridges is a bit different, we have included the cartridge printing theory in the following pages.

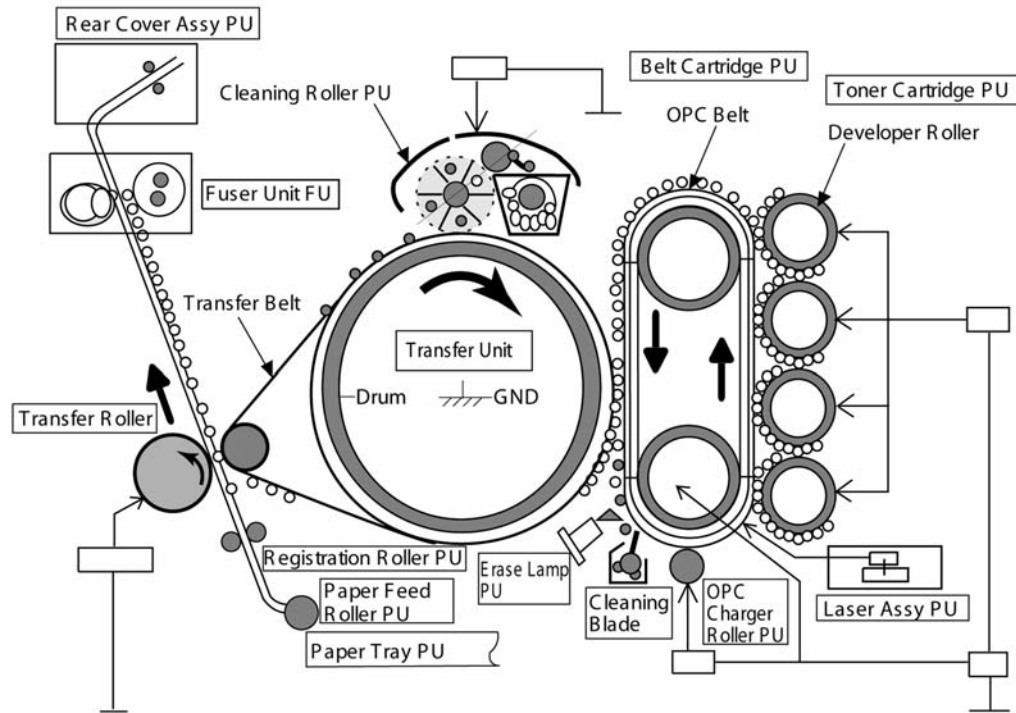

The above illustration shows a close-up of the components used in the printing process. Also shown are which components have voltages supplied by the power supply. For the actual color toner cartridge printing process, it is best explained as a series of stages or steps.

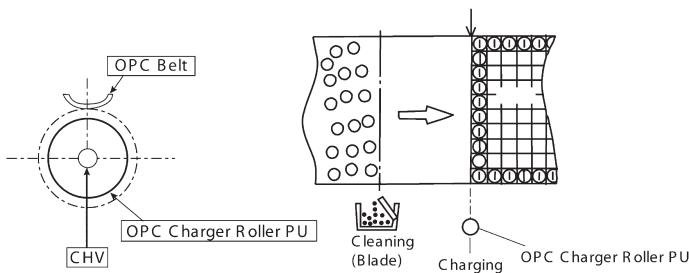

The **first stage** in the printing process is the Primary charging stage, the Primary Charge Roller (PCR) places a uniform negative DC voltage on the OPC belt surface. The amount of the negative DC voltage placed on the belt is controlled by the printer's intensity setting.

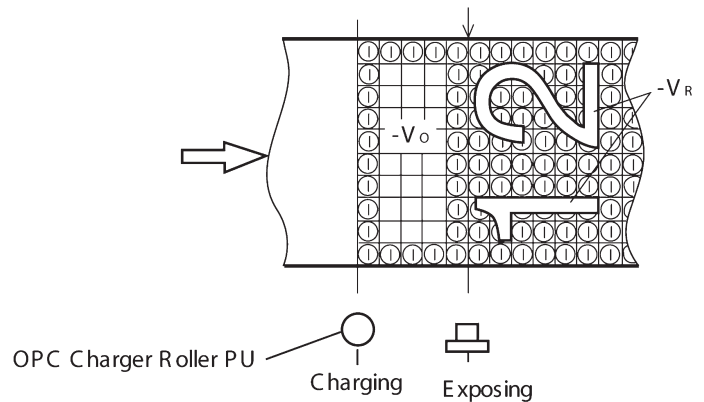

In the **second stage**, the laser beam is fired onto a rotating mirror (called the scanner). As the mirror rotates, the beam is reflected into a set of focusing lenses. The beam then strikes the belts surface, reducing the negative charge and leaving a latent electrostatic image on the drum. The areas where the laser did not strike the drum will retain the full negative charge. Here the number 12 is being printed.

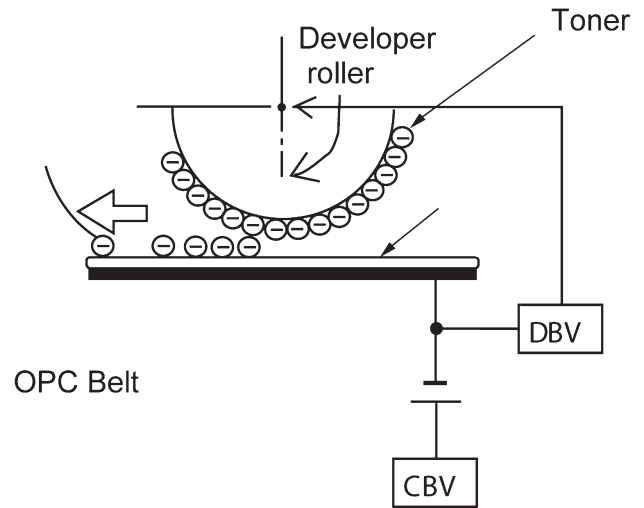
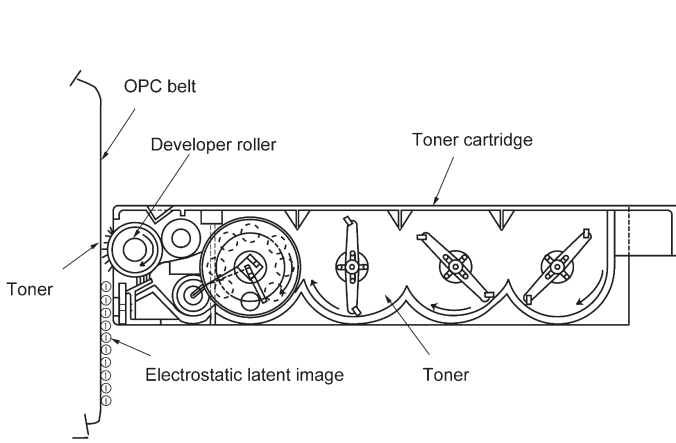

The **third or developing stage** is where the toner is made ready to transfer by the developing section (or supply chamber) of each color cartridge. The toner stirring blades start the process by turning inside the hopper. As they turn, the toner is moved to the feed roller and then to the developer roller. The developer roller has a charge placed on it which attracts an even layer of toner. The voltage that is placed on the developer roller is controlled by the printer's intensity setting, and causes either more or less toner to be attracted by the developer roller. This in turn will either increase or decrease the print density. The amount of toner on the developer roller is also controlled by the doctor blade, which uses pressure to keep the amount of toner on the roller constant.

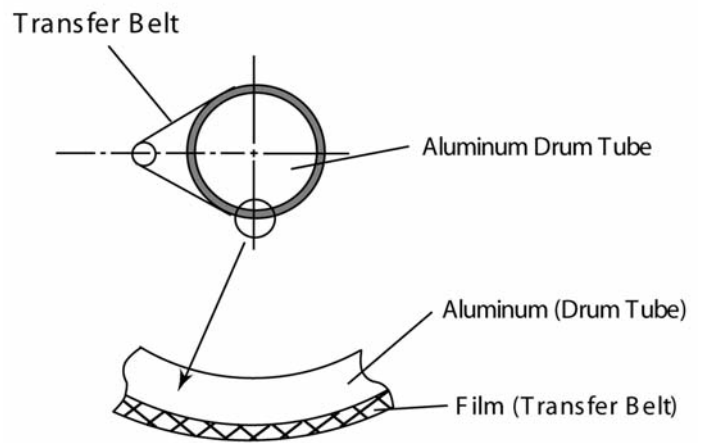
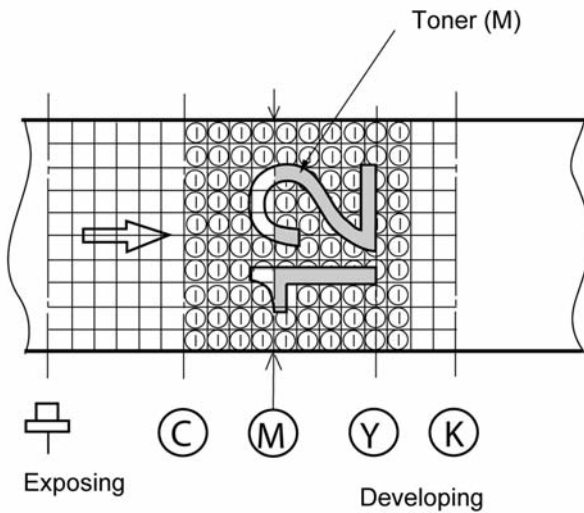

The **fourth stage** is the **first transfer stage**. As the laser exposed areas of the OPC belt approach the developer roller, the toner particles are attracted to the belt's surface due to the opposite voltage potentials of the toner, and laser exposed areas of the OPC belt.

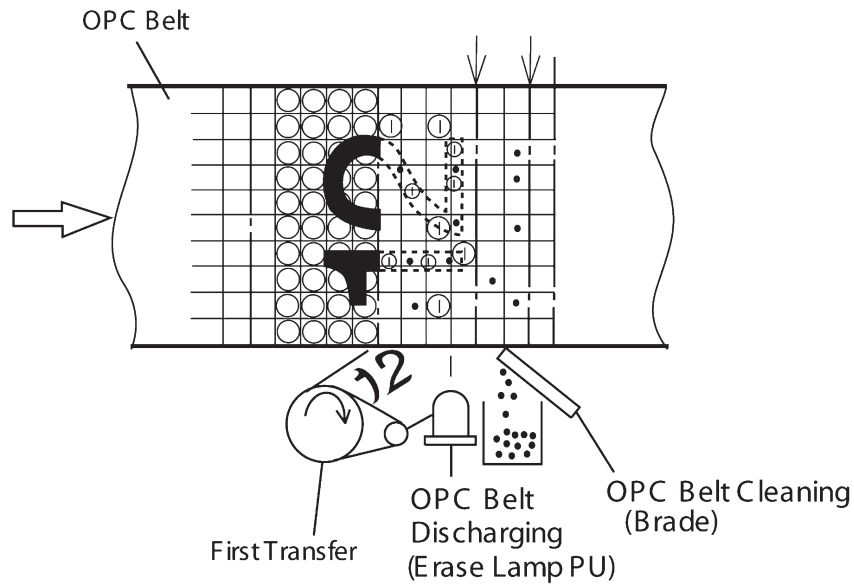

This is where there are some large differences from monochrome printers. The different color latent images are then transferred from each toner cartridge to the OPC belt in a specific sequence. The full complete image is then transferred to the transfer belt.

At this point a series of 6 LED lamps light up and bathe the OPC belt in light which neutralizes any remaining electrical charges and make the physical cleaning of the belt easier.

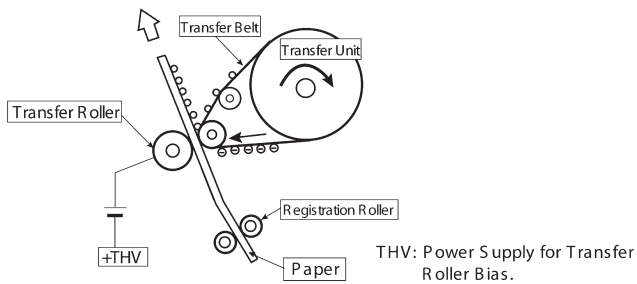

The **fifth stage** is the **final transfer stage** where the full image is transferred from the transfer belt to the paper using the difference in voltage potential as applied by the transfer roller.

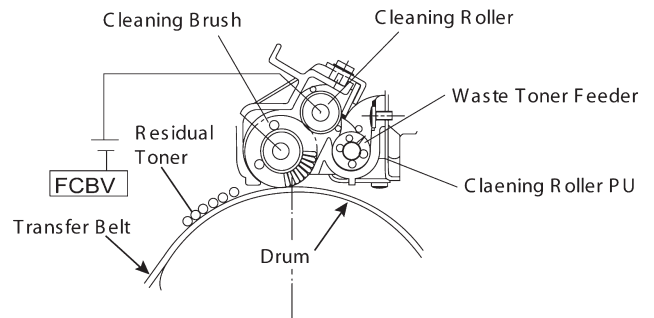

In the **sixth stage**, the image is then fused onto the paper by the fuser assembly.

The **final stages** are where the transfer belt is cleaned. The transfer belt is cleaned after every complete image has been transferred to the paper. A cleaning brush which has a positive charge placed on it removes the waste toner from the belt. The waste toner is transferred to the waste toner tank.

TONER CARTRIDGE INSTRUCTIONS

REQUIRED TOOLS

- Toner approved vacuum
- Phillips head screw driver
- Small jewelers Phillips screwdriver

REQUIRED SUPPLIES

- TN-04 toner (310g black, 210g color)
- Developer roller cover
- Soft, lint-free wipes

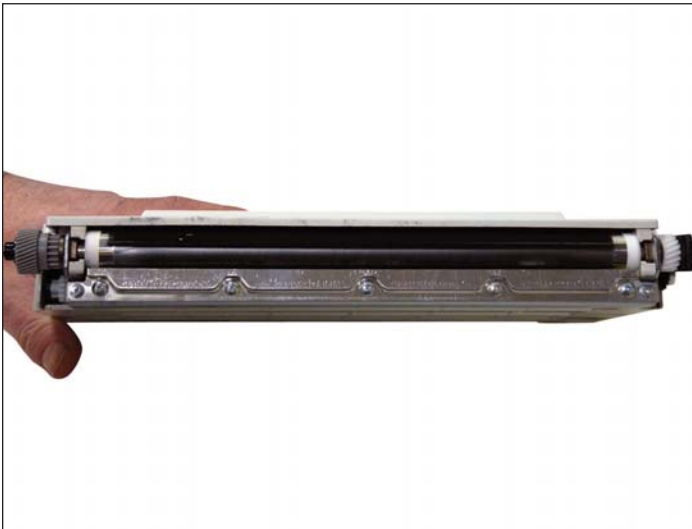

1. Remove the 2 silver screws from the outer edge of the doctor blade.



2. Lift up on the doctor blade side and remove the developer roller assembly.

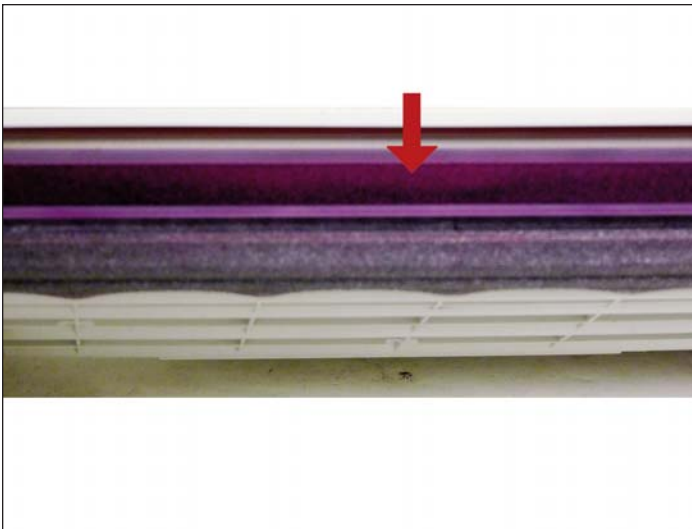

3. Dump out all remaining toner from the chamber. The fill plug in these cartridges is not removable. Blow out any remaining toner from the hopper paying special attention to the feed roller. It can become clogged (Impacted) with toner and over time this will interfere with the amount of toner fed to the developer roller

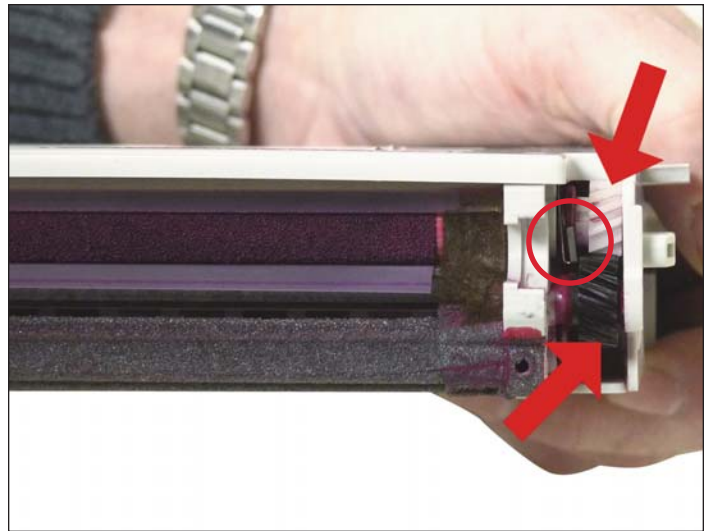
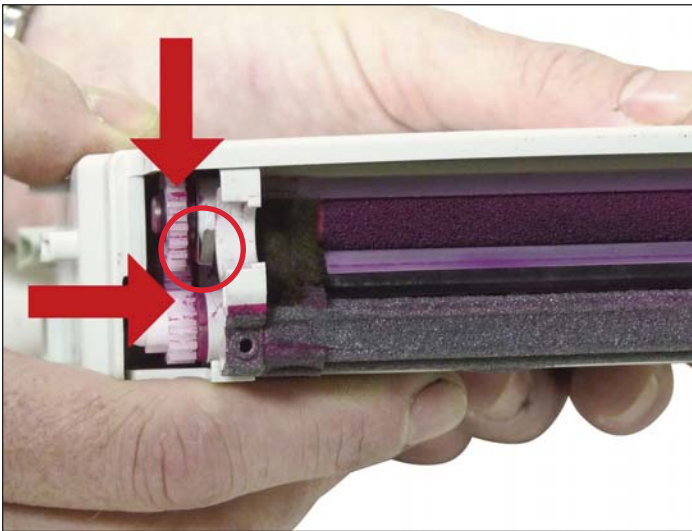

4. Make sure the gears on both sides of the cartridge are clean and turn freely.

NOTE: Doctor blade contacts (shown circled) need to come into contact with the doctor blade. Make sure the doctor blade contacts have continuity after the doctor blade is installed.



5. Fill the hopper with the appropriate color toner. While the cartridges all look the same, they are not interchangeable. Each color has a different set of plastic tabs.

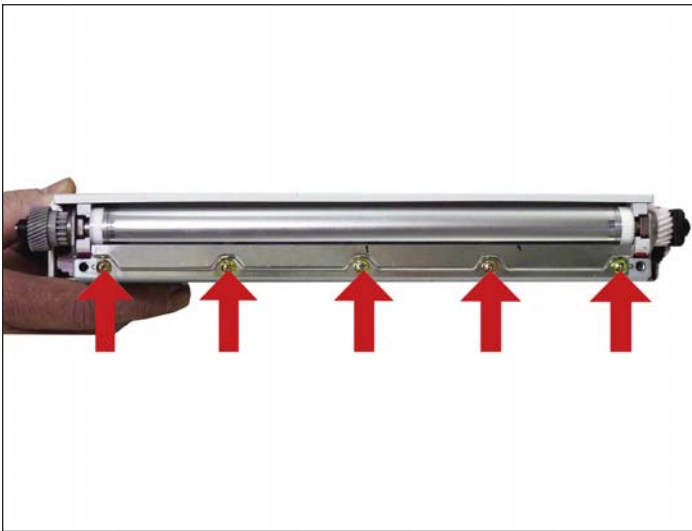

6. It is best not to take the doctor blade assembly apart, but if you do, use a gapping gauge to measure the gap by each of the five screws before removing any of them. Set the gap back to the proper distance when re-assembling the blade assembly.

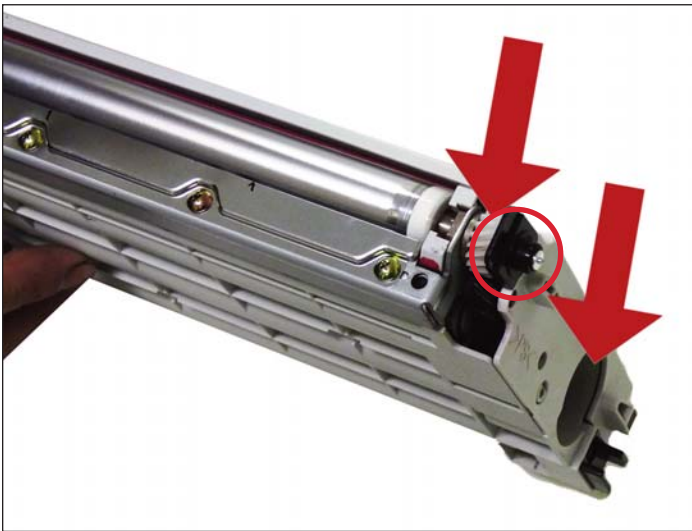

7. Install the developer roller assembly small gear to the fill plug side of the cartridge. Install the two outer screws.
NOTE: Make sure the black tab (shown circled) is pointing away from the cartridge.



8. Install the developer roller cover.

REPETITIVE DEFECT CHART

• OPC belt	380mm
• Transfer drum	379.94mm
• Paper pick up roller	125.6mm
• Fuser roller	125.6mm
• Back up roller	100.48mm
• Drum cleaning roller 2	78.50mm
• Transfer roller	62.80mm
• Cleaning roller	56.52mm
• Developer roller	56.52mm
• Paper exit roller	50.24mm
• Registration roller	42.39mm

The error codes are all in plain English so there is no need to go into them here.